

Wine Guardian environmental control systems...superior performance and reliability for all of your residential and commercial wine room conditioning needs. Self-contained, free-standing Wine Guardian Humidifiers increase humidity levels within any residential or commercial wine cellars.

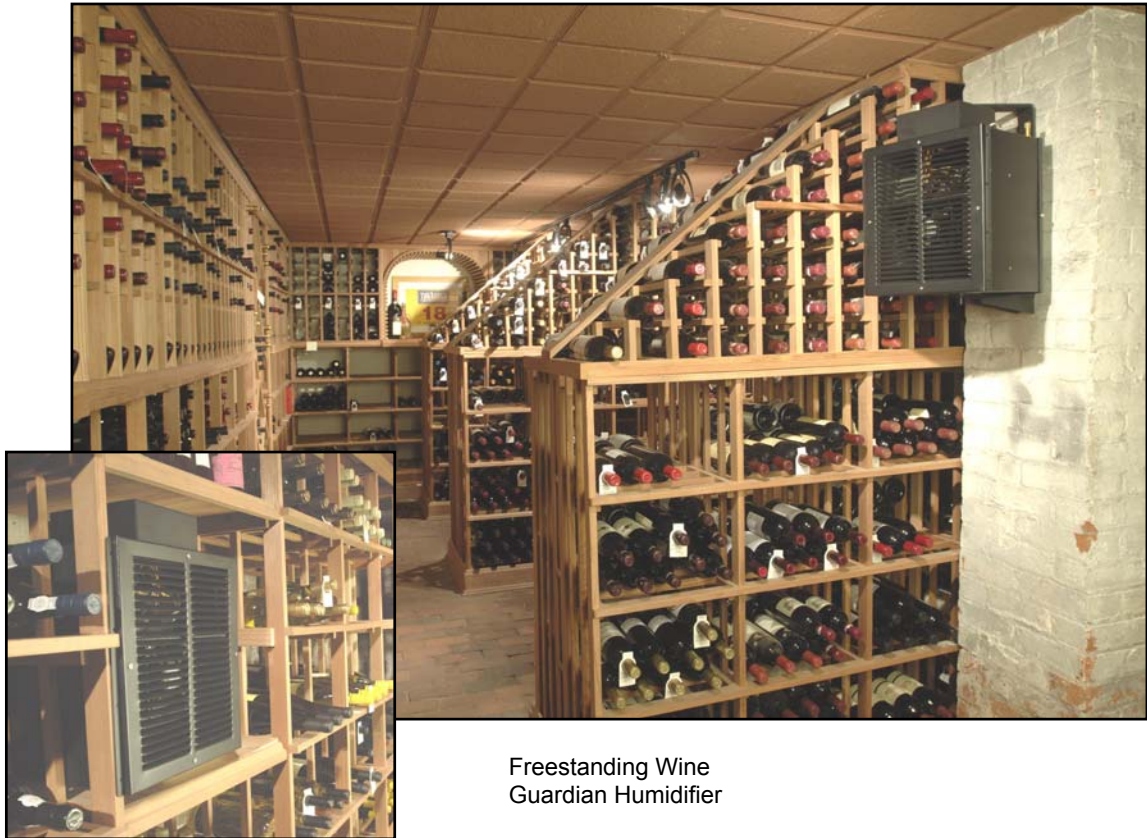

Freestanding Wine
Guardian Humidifier

Standard Features

- Drip pad-type humidification with removable, cleanable pad.
- Humidifier can be mounted as a free-standing unit within the wine cellar or Wine Guardian mounted.
- Lightweight, corrosion-resistant, all-aluminum outer body
- Integral fan for air circulation
- Removable supply grill and drip pad access cover for easy service
- Completely self-contained design with cellar mounted humidistat
- Factory tested prior to shipment
- Free-standing option plugs into any 115 volt electrical outlet
- 24/7 factory service hotline support



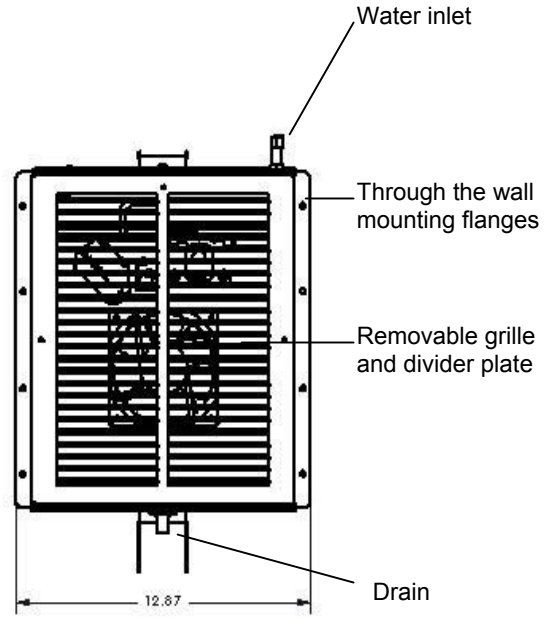
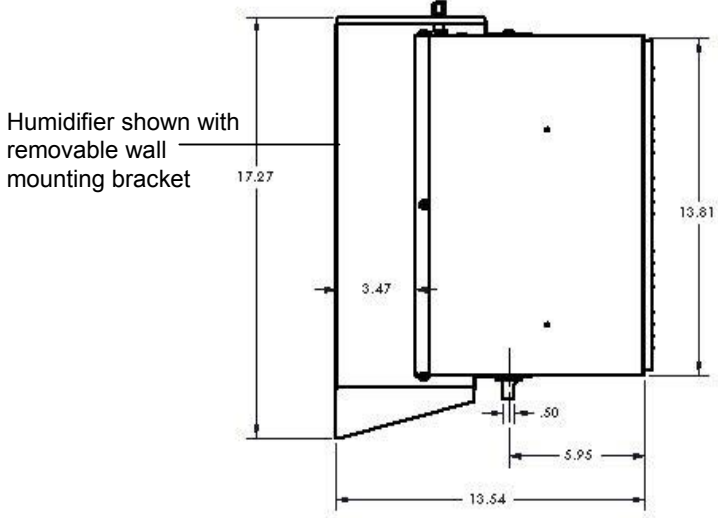
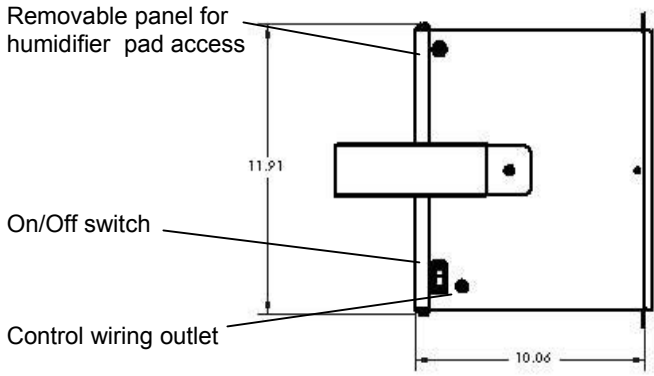

Wine Guardian Humidifier

Type		Removable Drip pad with integral fan
Supply water temp of 60 Deg F	gal./day	1.6
Supply water temp of 90 Deg F	gal./day	3.5
Supply water temp of 120 Deg F	gal./day	5.1
Controls		Cellar mounted digital humidistat
Power Requirements	V/P/H	115/1/60 as Free Standing, 24 Volt direct connected to WG

Air Innovations reserves the right to make changes to this document without prior notice at its sole discretion.